

6.3
U.O.N

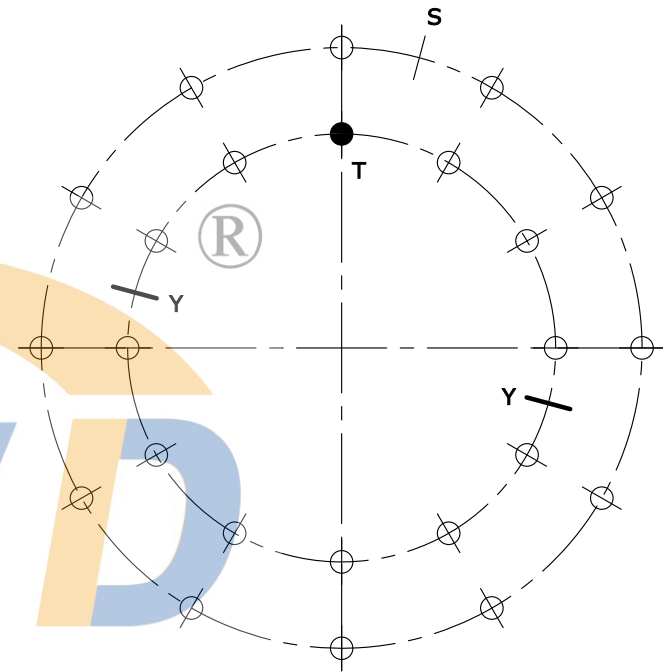
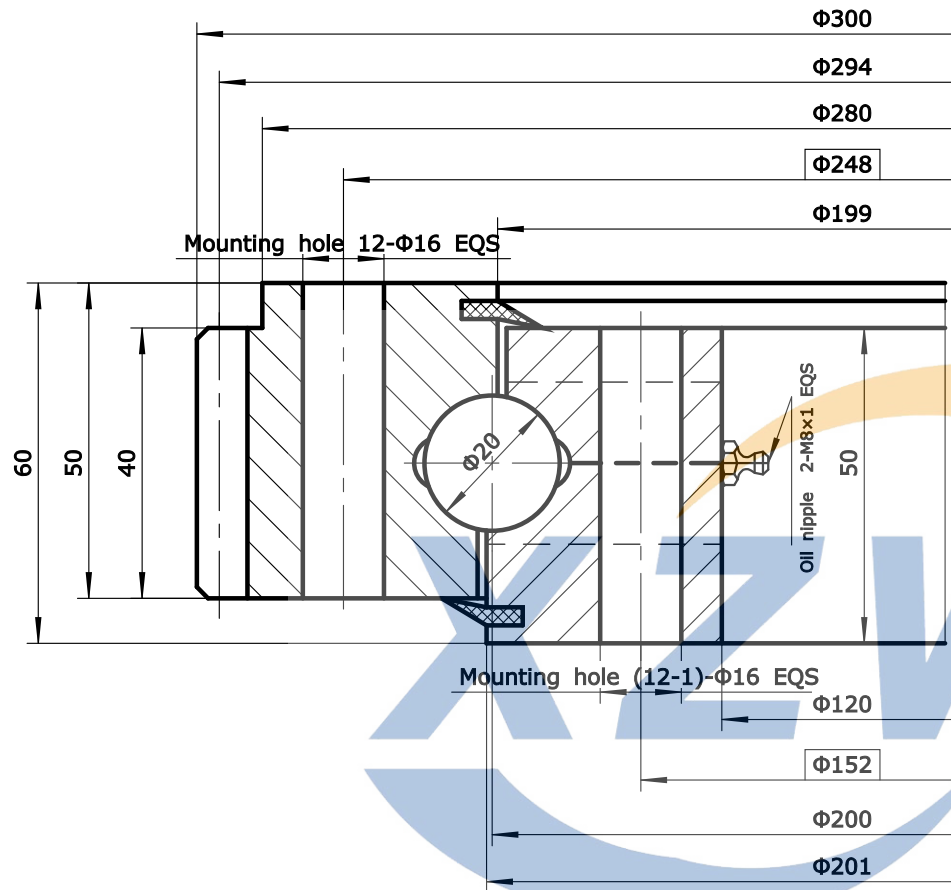

Notes:

1. Raceway of inner & outer ring induction hardened. hardness: 55~62HRC
Depth ≥ 3.0mm
2. Inner & outer ring quenched & tempered, hardness: 207~262HB

Gear Data				Design		Check		Model				
Module	m	3	Gear heat treatment requirements 50±5HRC	Date		Approve		011.20.200		Weight	24kg	
Teeth no	z	98						Name	Slewing Bearing	Qty	Scale	
Teeth pressure angle	α	20°	Precision(GB10095-88)	10	Qty	Size	Axial clearance	0.04~0.20	Total 1 page		The 1st page	
Modification coefficients	x	0			Inner ring mounting hole	12-1	Φ16	Radial clearance	0.04~0.20	Material		50Mn
Reduction coefficients	km	0			Outer ring mounting hole	12	Φ16			Technical processing standards without notes according to ...JB/T2300-2011		
Pitch diameter	d	294			Oil hole	2	M8×1			XUZHOU WANDA SLEWING BEARING CO.,LTD		
										Fax: +86 516 83309366 Fax: +86 516 83915766		
										http://www.slew-bearing.com		